

集装箱空箱堆高机

2-3层 5-6层 7-8层
Empty Container Handler

HELI
中国合力 提升未来



2-3层 5-6层 7-8层
集装箱空箱堆高机
Empty Container Handler

设计印刷 李可立印务 Fokeli Print 191206



安徽合力股份有限公司
ANHUI HELI CO., LTD.

地址: 合肥市经开区方兴大道668号
咨询电话: 0551-63689111
融资租赁: 0551-63689365
传真: 0551-63689365
网址: <http://www.helichina.com>
邮箱: sale@helichina.com

ADD: NO. 668 Fangxing Street, Economical Development Zone, Hefei, P.R. China
TEL: (86 551) 63639068 (America) 63639258 (Europe) 63639358 (Asia)
63662105 (Africa & Middle East) 63639530 (Warehouse Equipment)
63639531 (Wheel loader)
FAX: (86 551) 63639966
WEBSITE: <http://www.helichina.com>
Email: helihelichina.net



我们的实力 Our strength

安徽合力股份有限公司系安徽叉车集团有限责任公司核心控股子公司，1996年在上海证券交易所上市，注册资本6.168亿元，是我国目前规模最大、产业链条完整、综合实力和经济效益好的工业车辆研发、制造与出口基地。

Anhui heli co., LTD. Department of anhui forklift group limited liability company core subsidiary, listed on the Shanghai stock exchange in 1996, the registered capital of 616.8 million yuan, is our country at present, large scale and complete industry chain, good economic performance and comprehensive strength industrial vehicle research and development, manufacture and export base.



行业地位 Industry status

公司的叉车和零部件产品在国内同行业中规格最全、规模最大，叉车的综合性能处于国内同行业龙头地位，部分产品达到国际先进水平。各项主要经济指标已连续多年高居全国同行业之首。

Forklift and parts of products of the company in the country the most complete specifications and in the industry, the comprehensive performance of forklift truck in a domestic same industry leading position, some products reached the international advanced level. The main economic indicators has been for many years in the industry to high.



科研实力 The scientific research strength

公司技术中心是1995年由国家发改委等四部委首批认定的100家国家级“企业技术中心”之一。学科齐全，基础设施雄厚。

Company technology center is in 1995 by the national development and reform commission, the four ministries and commissions such as the first wave of 100 identified one of the state-level enterprise technology center. Discipline is complete, the infrastructure is strong.

我们的实力 Our strength



重要奖项 Important awards

近5年，公司自主研发的新产品获得6项科技进步奖，安徽省科技进步一等奖2项，机械工业科技进步二等奖一项。

In recent five years, the company independent research and development of new products to get six progress prize in science and technology, anhui science and technology progress award two, science and technology progress prize of mechanical industry.

设计手段 Design means

- ▶ 在整机的研制过程中借助计算机技术，运用了最新的设计方法和手段；车架、门架等关键结构件均经CAE有限元分析、模态分析、动力学仿真分析等优化设计手段，以精准的理论数据支持为设计基础，确保整车稳定性和结构强度均符合欧盟设计标准。
- ▶ The latest design method and means are applied with the help of computer technology in the research and development course of the complete machine. The key structures like frame and gantry etc have undergone the optimum design means such as CAE finite element analysis, modal analysis and dynamics simulation analysis etc and take the accurate theoretic data support as their design base so that the stability and the structure strength of the whole car conform to the European design standard.



A. 发动机 Engine

- ▶ **2-3层车型**
一汽锡柴高端柴油发动机，6缸涡轮增压，额定功率118KW，最大扭矩640Nm，该发动机采用优化的配气系统及先进的燃油系统，具有油耗低、噪音低、结构紧凑、动力输出平稳等优点。
- ▶ **Truck for 2-3 layers**
Xichai High-performance diesel engine with 6 cylinders turbo charger, 118kw rated power and 640Nm max torque is assembled on the truck. With optimized air distribution system and advanced fuel system, the engine has low oil consumption, low noise, compact structure, stable power output and so on.
- ▶ **5-6层车型**
采用进口CUMMINS QSB6.7柴油机，6缸涡轮增压，符合欧美非公路机动设备Ⅲ阶段排放标准（中国Ⅲ阶段），发动机的附件为专用件，保证发动机的正常使用与维护。
- ▶ **Truck for 5-6 layers**
Imported CUMMINS QSB 6.7 diesel engine is adopted. The engine has 6 cylinders turbo charger and meets American Tier III emission standard (Chinese Tier III). Accessories specialized for the engine are used to ensure engine normal maintenance and usage.
- ▶ **7-8层车型**
瑞典VOLVO公司TAD851VE发动机，符合欧Ⅲ（国Ⅲ）排放要求。低速扭矩大，响应快；燃油经济性好，相比Ⅱ阶段发动机，油耗下降2.5%；发动机CAN总线技术的应用，简化了车辆的整车线束，配置的发动机DCU，通过CAN总线与发动机实现交互，液晶仪表能够清晰显示发动机数据和故障信息；发动机所用附件如空滤器、消声器均为专用配置，提高发动机的使用寿命与可靠性。
- ▶ **Truck for 7-8 layers**
VOLVO TAD851VE engine meets EURO IIIA emission standard (China stage III). It has large torque in low speed and quick response. Compared with engine meeting II emission standard, oil consumption is reduced by 2.5% and it has good fuel efficiency. With CAN bus technology, the harness of the completed truck is simplified. Engine DCU is installed and interaction can be realized between DCU and engine through CAN bus. Engine data and fault can be display clearly on liquid crystal meter. Special engine assessments such as air cleaner and muffler can improve engine service lift and reliability.

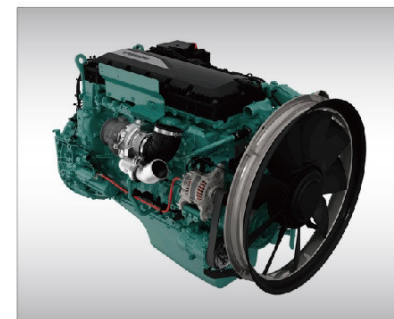
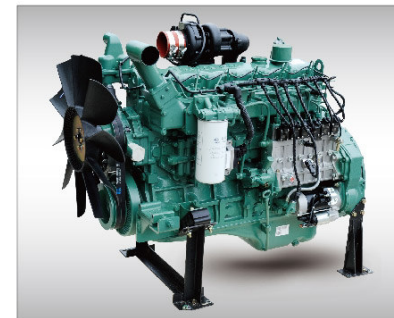

集装箱空箱堆高机

2-3层 5-6层 7-8层
Empty Container Handler

HELI



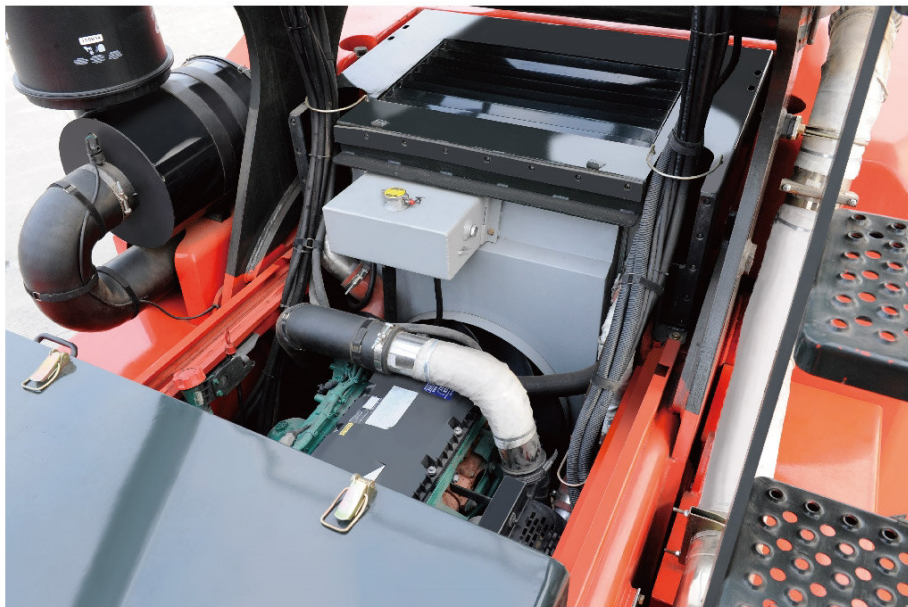

B. 热平衡温度好 Good thermal equilibrium temperature

- ▶ 在环境温度40度状态下，发动机水热平衡温度控制在100℃以下，传动油热平衡温度控制在90℃以下，液压油热平衡温度控制在80℃以下，较好的解决了因密封件老化导致的漏油漏水、发动机的早期磨损、变速箱无力（动力传递不足）等常见故障，各系统部件都能在良好的温度条件下工作，提高了整车的可靠性，降低故障率。
- ▶ Under the ambient temperature of 40 °C, the water thermal equilibrium temperature of the engine is controlled below 100 °C, the thermal equilibrium temperature of drive oil under 90 °C and the thermal equilibrium temperature of the hydraulic oil under 80 °C, which can solve in a better way the common problems of oil and water leakage due to the aging of the sealing elements, earlier abrasion of the engine and incapable gear box(power transmission is insufficient) etc so that the elements of all systems can work under the good temperature condition , thus raising the reliability of the whole car and lowering the fault rate.

C. 空滤过滤精度高 High air cleaner filter fineness

- ▶ 整车采用进口品牌空滤器，带有旋风式预滤器，两级过滤，过滤精度高，保证了发动机进气的清洁性。
- ▶ Air cleaner is assembled on the truck. With cyclone type pre-filter and two-end filter, the air cleaner has high filter fineness and thus engine air suction cleanness is ensured.





D. 驱动桥 Drive axle

▶ 2-3层车型

采用专用的驱动桥，性能可靠，技术领先，钳盘制动，拥有良好的性价比，抗污染能力强，散热好。

▶ Truck for 2-3 layers

Drive axle is assembled on the truck. The drive axle has reliable performance, advanced technology, caliper disc brake, nice cost performance, good anti-pollution ability, good cooling ability and so on.

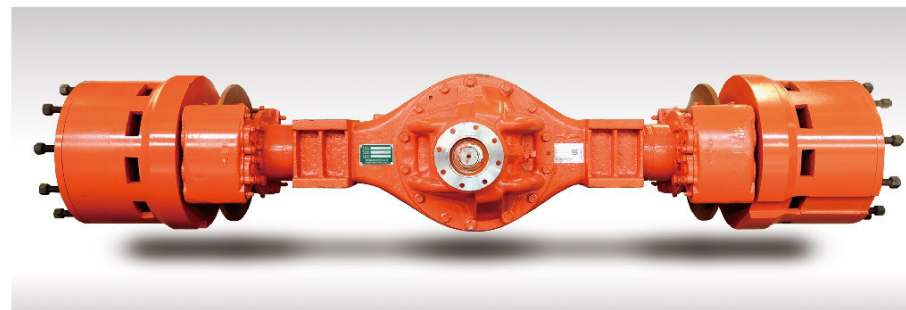

▶ 5-8层车型

采用德国KESSLER公司的重载驱动桥(包含停车制动器),该桥桥荷、制动扭矩大,安全可靠;制动器为多片式湿式制动器,全封闭免维护安全可靠,配备有钳盘式停车制动器。

▶ Truck for 5-8 layers

Drive axle: The heavy-duty drive axle (including parking brake) of KESSLER Company, Germany is used. The axle, with large capacity and brake torque, is safe and reliable. The multiple-piece wet type is fully enclosed, maintenance free, safe and reliable and is equipped with caliper disc parking brake.



E. 变速箱+变矩器 Transmission box+ Torque converter

- ▶ **2-3层车型**
HELI自制专用变速箱，档位分配为前二后二，电液换挡，可靠安全。
- ▶ **Truck for 2-3 layers**
HELI self-made special transmission box is assembled on the truck. The transmission box has two front gears and two rear gears, electro-hydraulic gear shifting and it is reliable and safe.
- ▶ **5-6层车型**
采用德国ZF3WG171变速箱。该变速箱采用多种控制程序集成于一体控制部件，能轻易实现各种控制操纵，并带有故障诊断仪，大大简化了维护与保养。
- ▶ **Truck for 5-6 layers**
ZF3WG171 transmission box is assembled on the truck. Control part integrated with multi control program on the drive axle can achieve all kinds of control operation easily. Fault diagnosis tester in the transmission box simplifies maintenance and service greatly.
- ▶ **7-8层车型**
采用德国ZF3WG211变速箱，该变速箱采用多种控制程序集成于一体控制部件，能轻易实现各种控制操纵，并带有故障诊断仪，大大简化了维护和保养。
- ▶ **Truck for 7-8 layers**
ZF3WG211 transmission box is installed on the truck. The control part with several control programs can realize all kinds of operations. It also has fault diagnosis which makes maintenance and service easier.

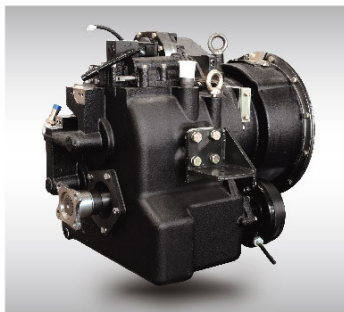

F. 液压系统 Hydraulic system

- ▶ **2-3层车型**
主要部件采用国际知名品牌，多路阀为先导控制的多路换向阀，操纵手柄远距离控制，操纵轻便省力舒适，减轻司机的操作疲劳强度。
- ▶ **Truck for 2-3 layers**
Main parts are world famous brand. Pilot controlled control valve is adopted on the truck; knob operation is easy which thus reduces operator fatigue.
- ▶ **5-6层车型**
主要部件采用国际知名品牌，多路阀为带有优先转向的先导控制的多路换向阀，国际知名品牌原装进口件，操纵手柄与多路阀分开，可实现远距离控制，操纵轻便省力舒适，安全性能好，减轻司机的操纵疲劳强度。国际知名品牌转向器。
- ▶ **Truck for 5-6 layers**
Main parts are world famous brand. The control valve has pilot control with steering priority. parts from world famous brand. Independent operation knob and control valve achieve long distance control. It is easy to operate and it is safe and comfort. World famous brand steering unit is assembled on the truck.
- ▶ **7-8层车型**
主要部件采用国际知名品牌原装进口件，高效可靠，单手柄操纵，先导远程控制，操纵轻便，简单省力，可减轻司机的操作疲劳强度；液压油路配强制冷却系统，可满足高强度作业的要求。
全液压负荷传感的液压系统；
合理的系统设计确保节能高效；
国际知名品牌转向器。
- ▶ **Truck for 7-8 layers**
Main parts are from world famous brand. It is operated with single handle and piloted control. It can relieve the fatigue of the drivers because of simple operation and energy saving. The hydraulic oil circuit equipped with forced cooling system can meet the requirements of high intensity work. Fully hydraulic load sensing hydraulic system. Reasonable design ensure energy saving and high efficiency. World famous brand steering unit is assembled on the truck.



G. 制动系统 Braking system

- ▶ 2-3层车型
气液综合钳盘式制动系统，刹车距离短，可靠性高，维护成本低。
- ▶ Truck for 2-3 layers
Brake system: the brake system is of gas-liquid caliper disc type. It has short brake distance, high reliability and low maintenance cost.
- ▶ 5-8层车型
全液压动力制动系统
制动阀等制动原件选用国际知名品牌产品；接头、胶管等管路元件选用品牌产品，配有多级安全保护装置，安全可靠。
行车制动低压报警；
过温报警；
系统堵塞报警。
- ▶ Truck for 5-8 layers
Fully-hydraulic dynamic braking system
The braking elements such as brake valve etc use the products from world famous brand. The connectors and rubber pipes etc choose the brand products, USA and equipped with multi-stage protection devices, so they are safe and reliable.
Service brake low pressure alarm.
Over-temperature alarm.
System obstruction alarm.

H. 电气系统 Electric system

- ▶ 控制部分采用模块化、高度集成的中央配电箱设计，配电箱应用先进的可编程3D矩阵技术，方便变更。整车采用LED灯具，具有高亮度、低能耗、寿命长等优点；整体式仪表台布局和CAN BUS总线技术应用，使得车辆信息显示全面、清晰，阅读方便；采用国际知名品牌的接插件，具有较好的防尘、防溅功能。设计简洁明了，系统的可靠性高。
- ▶ The control part adopts modularized and high integrated central distribution box using advanced and programmable 3D matrix technology which is easier for change. LED lamps with bright lighting, low consumption and long service life are installed. With integrated dash board and CAN BUS technology, truck information is displayed clearly and it is easy to be read. World famous brand connector is dust proof and water proof. The design is concise and easy for use. The system is highly reliable.



I. 双启动,双熄火控制 (7-8层车型) Dual-starting and dual flameout (Truck for 7-8 layers)

- ▶ 该车型具有双启动(钥匙启动,屏幕开关启动),双熄火控制(钥匙熄火,屏幕开关熄火),实现人机操纵的方便性。
- ▶ The truck has dual starting (key starting, screen switch starting) and dual flameout (key flameout and screen switch starting) controls to facilitate operation.



模块化设计,减少故障点,提高可靠性
防尘、防水

Modular design to reduce the fault points and raise the reliability
Dust and water resistance



J. 散热系统 Heat radiation system

- ▶ 采用知名品牌散热器，该散热器应用油水复合技术，单层布置，便于冲洗和保养，优越的散热性能确保各系统部件都能在良好的温度条件下工作，有效的降低了整车故障率，提高整车可靠性；
发动机水、中冷、变速箱油各自独立的复合散热器；
自动钎焊技术，铝质散热器，质量可靠，散热功率大。
- ▶ Well-known brand radiator is used, which applies water and oil compound technology, is arranged in single layer and facilitates flushing and maintenance. The superior heat dissipation performance ensures that the parts of each system can work under the good temperature condition, thus effectively cutting down the fault rate and raising the reliability of the whole car.

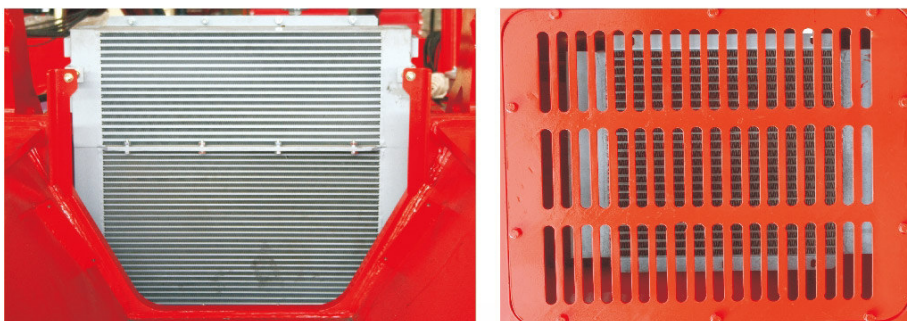

HELI

K. 驾驶室内座椅采用全悬浮减震结构，可做全方位的调节 The drive seat in the drive cab adopts full suspension and vibration attenuation structure and can be adjusted in all directions

- ▶ 驾驶室内座椅采用全悬浮减震结构，可做全方位的调节；各操作踏板、手柄位置按人体工程学原理设计，可大大降低劳动强度；加大司机室设计，四面全明玻璃，视野开阔，配冷暖空调。
- ▶ The drive seat in the drive cab adopts full suspension and vibration attenuation structure and can be adjusted in all directions. Each operation pedals and handle position are designed according to the principle of human engineering and can greatly reduce the labor intensity. The drive cab is designed with transparent glasses on all sides and wide field of vision and is furnished with air conditioner as well.



利用优化设计手段进行加宽门架设计，改善了整车的视野，同时增加了门架的抗扭性，起升下降更加平稳可靠。

To broaden the gantry design by making use of the optimum design means ,which improves the field of vision of the whole car and strengthens the resistance to torsion of gantry as well so that the ascending and descending are more smooth and reliable.



L. 吊具 Spreader

- ▶ **2-3层车型**
吊具为合力针对20英尺集装箱及灌箱的吊装专门设计，整体采用优质结构钢焊接，强度高、视野好。
- ▶ **Truck for 2-3 layers**
Spreader is specially designed for 20 feet containers and pouring boxes. It is welded by high quality structural steel and it has good strength and view.
- ▶ **5-8层车型**
采用瑞典ELME公司的新型吊具，该吊具采用优质钢制造，单筒式结构，强度高，视野好，带安全互锁功能。可实现侧移、伸缩和开闭锁等动作，并有吊具状态指示，辅助灯光照明等功能。
- ▶ **Truck for 5-8 layers**
The new type spreader from ELME Company, Sweden is used, which is made with high quality steel and of single-tube structure and has high strength, good field of vision and safe interlocking function. It can realize the actions of sidesway, expansion, contraction, unlocking and locking etc and has the functions of spreader status indicator and auxiliary lamplight lighting etc.

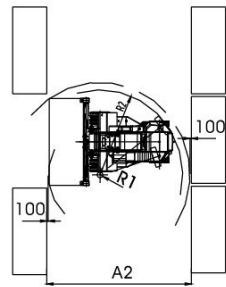
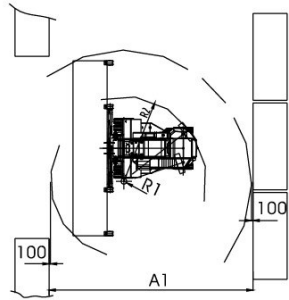
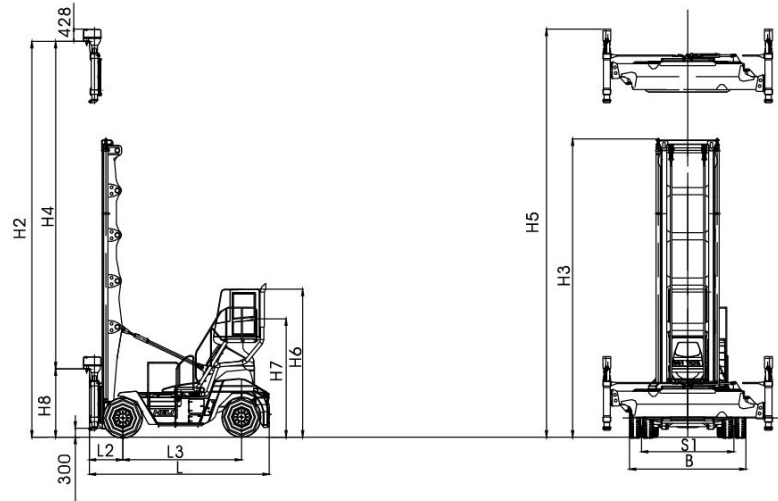

整车负荷图

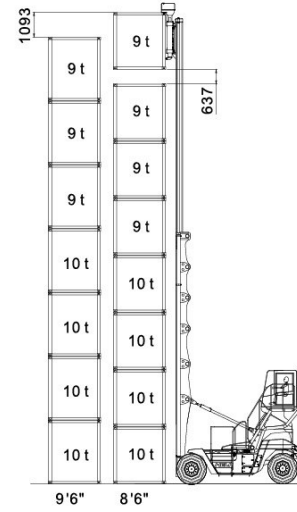

整车负荷图

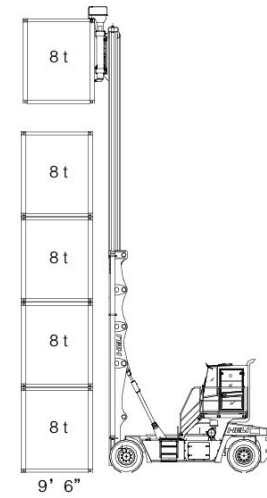
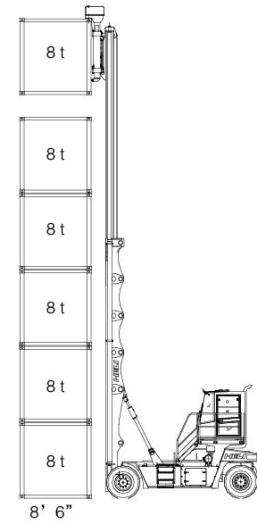
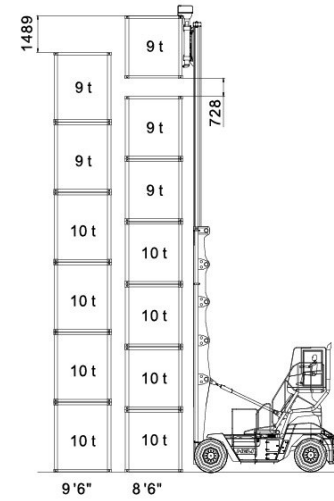

M. 现场使用灵活, 轻巧 Flexible and handy operation on site



N. 合力智能车队管理系统(选配) HELI smart fleet management system (optional)

- ▶ 车辆定位
- ▶ 远程诊断
- ▶ 远程监控
- ▶ 维保提示
- ▶ 电池管理
- ▶ 统计报表
- ▶ 车辆管理
- ▶ 身份识别(选配)
- ▶ 称重管理(选配)
- ▶ Vehicle positioning
- ▶ Remote diagnosis
- ▶ Remote monitoring
- ▶ Maintenance reminder
- ▶ Battery management
- ▶ Statistical form
- ▶ Vehicle management
- ▶ Identification recognition (optional)
- ▶ Weight management (optional)



O. 型号说明 Model description

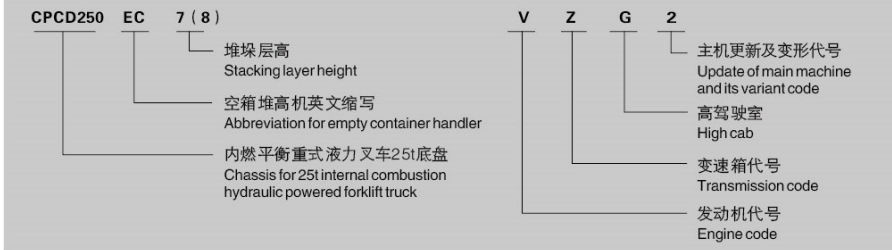

性能参数 Performance specifications

型号	Model			CPCD120EC2-WX1 CPCD120EC2-CU	CPCD120EC3-WX1 CPCD120EC3-CU
额定起重量	Rated capacity	Q	kg	4500	
载荷中心距	Load center	C	mm	1220	
最大堆高层数	Max. handling layers			2(8" 6' /9" 6')	3(8" 6)
可起吊集装箱长度	Length of container lifted		ft	20	
最大转锁高度	Max. Rotary lock height	H2	mm	6245	8245
最小转锁高度	Min. rotary lock height	H8	mm	2245	
门架倾角(前后)	Mast tilt angle (front/rear)		deg	6/12	3/6
吊具侧移量	Lateral displacement of spreader		mm	± 150	
最大行驶速度(空载/满载)	Stall speed		km/h	29/27	
最大起升速度(满载/空载)	Max. lifting speed (loaded/unloaded)		mm/s	350/370	
最大下降速度(满载/空载)	Max. descending speed (loaded/unloaded)		mm/s	300 ≤ 实测值 ≤ 600	
爬坡度(满载)	Gradeability (loaded)		%	28	
轴距	Wheel base	L3	mm	3000	
轮距前/后	Tread (front/rear)	S1/S2	mm	1950/2050	
长(带属具)	Length(with attachment)	L	mm	5060	
宽	Width	B	mm	2520	
高(门架缩回)	Height (mast retraction)	H3	mm	3715	4815
最小转弯半径	Min. turning radius		mm	5000	
发动机 Engine 柴油机 Diesel engine	制造商/型号	Manufacturer/Model		锡柴CA6DF3/CUMMINS QSB6.7	
	额定功率/额定转速	Rated output/Speed		kW/rpm 118/2200/119/2300	
	最大扭矩/转速	Max. Torque/Speed		Nm/rpm 640/1300-1700/732/1500	
变速箱 Gearbox (变速器) Torque converter	制造商/型号	Manufacturer/Model		合力自制变速箱	
	变速档数(前进/后退)	Shift gears (forward/backward)		2/2	
	换挡型式	Shift type		电液换挡	
轮胎 Tire	前轮规格	Front wheel size		11.00-20-18PR	
	后轮规格	Rear wheel size		11.00-20-18PR	
	气压(前轮/后轮)	Air pressure (front/rear)		kPa 900/900	

性能参数 Performance specifications					
型号	Model			CPCD180EC5-C1Z	CPCD180EC6-C1Z
额定起重量	Rated capacity	Q	kg	见负荷图 See load diagram	
载荷中心距	Load center	C	mm	1220	
最大堆高层数	Max. handling layers			5(8" 6" /9" 6")	6(8" 6)
可起吊集装箱长度	Length of container lifted		ft	20/40	
最大转锁高度	Max. Rotary lock height	H2	mm	15220	16300
最小转锁高度	Min. rotary lock height	H8	mm	2300	
门架倾角(前后)	Mast tilt angle (front/rear)		deg	3/3	
吊具侧移量	Lateral displacement of spreader		mm	±300	
最大行驶速度(空载/满载)	Stall speed		km/h	27/25	
最大起升速度(满载/空载)	Max. lifting speed (loaded/unloaded)		mm/s	420/460	
最大下降速度(满载/空载)	Max. descending speed (loaded/unloaded)		mm/s	300≤实测值≤600	
爬坡度(满载)	Gradeability (loaded)		%	30	
轴距	Wheel base	L3	mm	4000	
轮距前/后	Tread (front/rear)	S1/S2	mm	2800/2000	
长(带属具)	Length(with attachment)	L	mm	6000	
宽	Width	B		6065	
高(门架缩回)	Height (mast retraction)	H3	mm	8079	9379
最小转弯半径	Min. turning radius		mm	5400	
发动机 Engine 柴油机 Diesel engine	制造商/型号	Manufacturer/Model		CUMMINS/QSB6.7	
	额定功率/额定转速	Rated output/Speed	kW/rpm	142/2300	
	最大扭矩/转速	Max. Torque/Speed	Nm/rpm	929/1500	
变速箱 Gearbox (变矩器) Torque converter	制造商/型号	Manufacturer/Model		ZF/3WG171	
	变速档数(前进/后退)	Shift gears (forward/backward)		3/3	
	换档型式	Shift type		自动Automatic	
轮胎 Tire	前轮规格	Front wheel size		12.00-20-20PR	
	后轮规格	Rear wheel size		12.00-20-20PR	
	气压(前轮/后轮)	Air pressure (front/rear)	kPa	880/880	

性能参数 Performance specifications					
型号	Model			CPCD250EC7-VZG2	CPCD250EC8-VZG2
额定起重量	Rated capacity	Q	kg	见负荷图 See load diagram	
载荷中心距	Load center	C	mm	1220	
最大堆高层数	Max. handling layers			7(8'6")	8(8'6")
可起吊集装箱长度	Length of container lifted		ft	20/40	
最大转锁高度	Max. Rotary lock height	H2	mm	18865	21365
最小转锁高度	Min. rotary lock height	H8	mm	2255/2300	
门架倾角(前后)	Mast tilt angle (front/rear)		deg	3/3	
吊具侧移量	Lateral displacement of spreader		mm	±500/±600	
最大行驶速度(空载/满载)	Stall speed		km/h	24/22	
最大起升速度(满载/空载)	Max. lifting speed (loaded/unloaded)		mm/s	520/600	
最大下降速度(满载/空载)	Max. descending speed (loaded/unloaded)		mm/s	300≤实测值≤600	
爬坡度(满载)	Gradeability (loaded)		%	28	
轴距	Wheel base	L3	mm	4250	
轮距前/后	Tread (front/rear)	S1/S2	mm	3290/2395	
长(带属具)	Length(with attachment)	L	mm	6440	
宽	Width	B		6065	
高(门架缩回)	Height (mast retraction)	H3	mm	10370	11620
最小转弯半径	Min. turning radius		mm	5920	
发动机 Engine 柴油机 Diesel engine	制造商/型号	Manufacturer/Model		Volvo/TAD851VE	
	额定功率/额定转速	Rated output/Speed	kW/rpm	185/2200	
	最大扭矩/转速	Max. Torque/Speed	Nm/rpm	1160/1350	
变速箱 Gearbox (变矩器) Torque converter	制造商/型号	Manufacturer/Model		ZF/3WG211	
	变速档数(前进/后退)	Shift gears (forward/backward)		3/3	
	换档型式	Shift type		自动Automatic	
轮胎 Tire	前轮规格	Front wheel size		14.00-24-28PR	
	后轮规格	Rear wheel size		14.00-24-28PR	
	气压(前轮/后轮)	Air pressure (front/rear)	kPa	880/880	

- 合力产品不断更新和改进中，合力保留在没有事先告知用户的情况下，更改整体参数及设计的权利。
- 文中插图不一定是该机型的标准款，插图中产品配置和外观颜色与实际机型存在差异，以实物为准。

- Our products are constantly updated and improved. Parameters and design are subject to change without prior notice.
- The configuration and color of the products in figures may be different from the actual delivered model. Please in kind prevails.